

SHARPFEST S900 TOOL GUIDE GOUGE SHARPENING SYSTEM

SET UP PROCEDURES

A NEW WAY TO ACCURATELY AND SAFELY SHARPEN BOWL AND SPINDLE GOUGES.

Patented tool sharpening guide system that creates automatic mirror image side grinds. Same angles, depth of grind and smooth finish are reproducible every time.

Added Safety:

This guide system helps keep the gouge on the grinding wheel, preventing accidental run off that can result in injury to your hand. It also controls the placement of the gouge to the center of the wheel, helping to eliminate jamming the gouge tip into the grinding wheel - which can damage or even destroy the wheel.

KEY FEATURES

Safety: Keeps gouge on grinding wheel and allows hands to be away from grinder while sharpening
Creates consistent and repeatable professional grinds with every sharpening
Immediately adapts to other locking bases without modification
Available with *Holding Base* designed to prevent slipping with minimum tightening
Gouge holding head uses a bearing to lock down the tool: finger tightening creates a very secure non-slipping lock
Built in measuring device provides an adjustable and convenient way to consistently set your tool in the jig
Grinding angles are quickly and easily set
Various angles are possible with easy to set adjustment features
Heavy duty design provides long term use

SAFETY PRECAUTIONS

Always use Eye Protection
Keep hands away from grinding wheel when rotating.
Gouge may become hot and will be very sharp
Do not use if modified or damaged.
Follow safety instructions accompanying your specific grinder.

GRINDER MOUNTING PROCEDURES

Grinding Wheel specifications recommended for optimal results: 6" to 8" wheel, 1" Thick, 60 Grit

1. Mount the forward edge of the grinder base as close as possible to the forward edge of mounting surface to allow for maximum adjustment. The grinding wheel should be square with the front edge of the mounting base.
2. A minimum clearance of 2 ½" is required from the bottom of the grinder wheel guards to mounting surface to allow for *Holding Base* mounting. The grinder may need to be raised with a spacer to achieve this clearance.

GRINDER MOUNTING SET UP

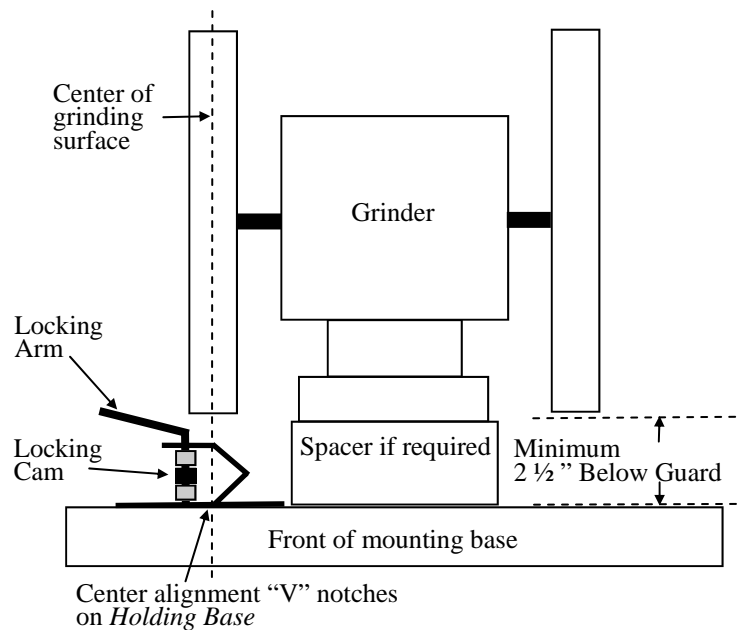

HOLDING BASE MOUNTING PROCEDURES

1. The Holding Base must be square and centered with the grinding wheel and approximately 3/4" back from the grinding surface.
 2. Using a square, mark the center of the grinding surface on the mounting surface. Using a square, draw a line from the forward edge of the mounting surface under the grinding wheel. This line should now run directly under the center of the grinding surface on the mounting base surface.
 3. Referencing that line, center V notches at front and back of the Holding Base with that line. Confirm base is square with grinding wheel and 3/4" back from grinding surface.
 4. Screw down in the center of oval holes of the Holding Base. This will allow for adjustment in step 5. Use flat washers to insure base does not move during tightening.
 5. Insert the Slide Arm into base and insert Tool Holder Swivel Arm into Swivel Block. Insert Gouge into tool holder and move the Slide Arm into the Base Holder until the Gouge tip rests against center of grinder wheel. Rotate Tool Holder left and right: the tip of the Gouge should remain in the center of the grinding wheel or move equal distance from center of grinding wheel.
 6. Screws may be loosened to correct misalignment of the mounting base. Use the back V notch to ensure square.
 7. Tighten all screws and confirm Holding Base is secure.
- See page to customize set up adjustment

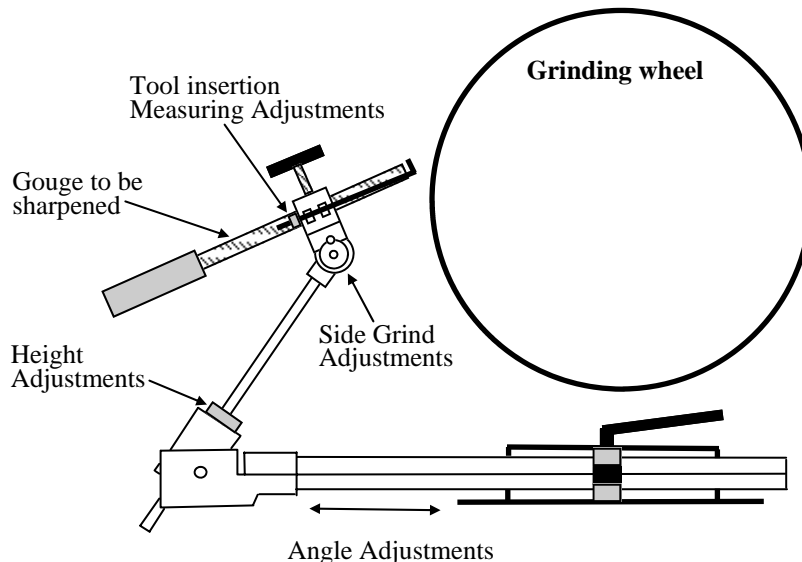
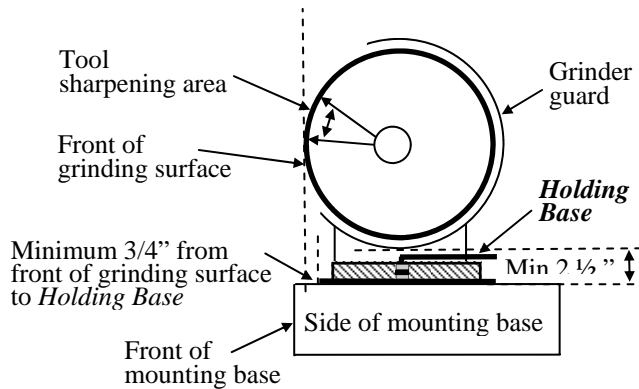

5 STEP ADJUSTMENT PROCEDURE

Five Easy Steps:

1. Insert Gouge or *Angle Set Up Tool*
2. Set Side Grind adjustment
3. Set Grind Angle Adjustment
4. Set Tool Height Adjustment
5. Test before grinding

#1 Insert gouge *Angle Set Up Tool* or in tool holder

1. Insert your gouge or *Angle Set Up Tool* (see page 14 to create your tool) into tool holder approximately 2" beyond holder end.
2. The built-in measuring device provides consistent settings and is preset at 2". After setting, rotate device out of way.
3. Finger tighten top knob until secure. **Caution:** Over tightening will damage hold down bearing.
4. Ensure top flutes of gouge are square with hold down bearing surface.

#2 Side Grind Adjustments

1. The angle of this adjustment determines the length of the grind on the sides of the flutes.
2. Basic set up position: align notch with hole; this will meet most woodturning needs.
3. For shorter side grinds, increase the angle by loosening the Side Grind Adjustment bolt and tipping gouge handle down; reverse for longer side grinds.

#3 Grind Angle Adjustments

1. Move the *Slide Bar* in or out to change the angle of the grind.
 2. Bring your gouge or *Angle Set Up Tool* against the grinding wheel by moving the slide bar into the holding base until angle matches grinding wheel.
 3. *Angle Set Up Tool:* See instructions on page 14 to make your own tool. We suggest basic angles to meet most requirements: 35° to 45° for Bowl Gouges and 50° to 60° for Spindle Gouges.
- You can match or create new customized grinding angles by moving the *Slide Bar* in or out of the *Holding Base*.

#4 Height Adjustment

1. The gouge or *Angle Set Up Tool* should meet the grinding wheel slightly above diameter center.
2. Adjust the height by loosening the collar on the swivel arm and move the tool holder until the gouge or *Angle Set Up Tool* is in the desired location on the grinding wheel; slide collar down to rest against swivel block and retighten.
3. Recheck the grind angle and readjust *Slide Bar* if required.
4. If *Angle Set Up Tool* was used, replace with gouge to be sharpened at this time.

#5 Test before grinding

1. Place tip of gouge against the grinding wheel.
2. Rotate tool back and forth to ensure gouge stays on wheel and matches grind desired.
3. If the tool does not stay on the grinding wheel as desired when using customized settings, the gouge may need to be measured shorter or longer than the standard 2" or angles readjusted towards the Basic Setting.
4. **Caution:** Extreme angles, very long side grinds, or other than the standard 2" measure may cause the tool holder to hit the grinding wheel.

GRINDING YOUR GOUGE

1. Pull gouge away from grinding wheel, ensure there are no obstructions and turn on grinder.
2. With your hands on the gouge handle – safely away from grinding wheel, slowly rest the tip of the gouge against the grinding wheel.
3. Once the desired grind angle has been achieved, rotate right and left to achieve desired side grinds.
4. **Caution:** Tool Holder may hit the grinding wheel if tool holder is rotated beyond the grinding wheel surface.
See step #2 of Set Up if a longer side grind is desired.

CREATING YOUR OWN ANGLE SET UP TOOL

An *Angle Set Up Tool* may be used to verify or create a specific grind angle. Create a flat surface on the top of a 1/2" dowel that is at least 4" long. Using a miter saw cut the desired angle to duplicate. We recommend 35° to 45° for a Bowl Gouge and 50° to 60° for a Spindle Gouge. Insert into tool holder as you would a gouge and match angle against grinding wheel.

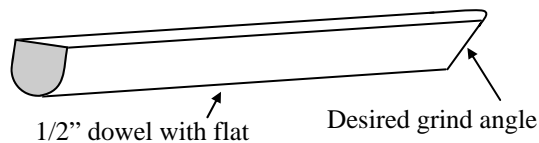

CUSTOMIZE YOUR SET UP

Customize Tool Holder to Left Hand operation

Remove *Grind Angle Adjustment Screw* and rotate *Tool Holder*. Basic Side Grind Angle may now be adjusted to match “notch to hole for lefties”. Turn *Measuring Device* around.

Customize Holding Base locking positions

Holding Base Locking Arm locks in one direction either push or pull depending on which way the base is mounted. The locked position can be changed by adjusting the center cam and turning the cam over to change the locking direction.

Holding Base Hex Key Holder

Holding Base has holes to insert short end of Hex Key arm into and long arm nest between two raised “^”s.

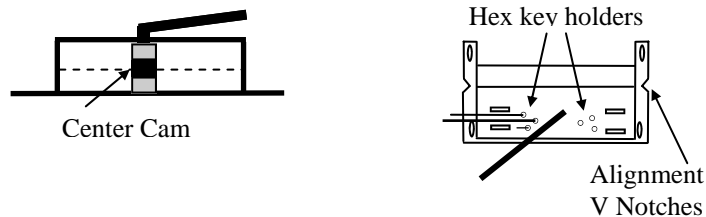

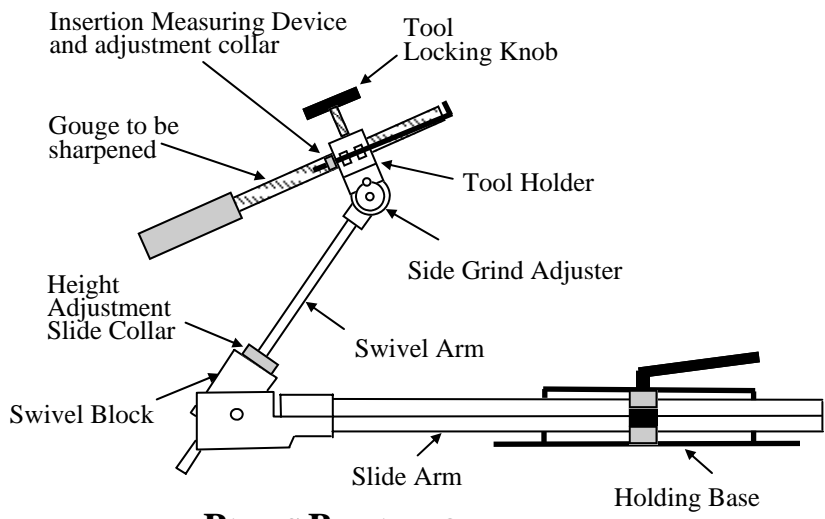

PARTS BREAKDOWN